

# SLIDING GATE MOTOR UP TO 800KG

ERMIS-8



# ERMIS-8 SLIDING GATE MOTOR UP TO 800KG

## 1. Important Safety Information

Carefully read and follow all safety precaution and warnings before attempting to install and use this operator, incorrect installation can lead to severe injury.

- The gate operator should be installed by a qualified technician; otherwise, serious personal injury or property damage may occur.
- When opening or closing the gate, do not attempt to walk or drive through the gate.
- Children should not be allowed to play near or operate automatic gates.
- The automatic gate operator must be grounded.
- Install the gate operator on the inside of the property, DO NOT install it on the outside of the property where the public has access to it.
- Be careful when in close proximity to moving parts where hands or fingers could be pinched.
- Do not allow control devices to be placed so that a person can access them by reaching through the gate.
- In the event of power failure, an emergency release key allows you to operate the gate manually.
- Do not attempt to tune the gate by placing your hand, arm or other body part in the path of the gate, as serious injury could result. Damage to the gate operator motors may also occur by placing a heavy immovable object in the path during the testing phase. Instead, place a light object in the path (e.g., a chair or trash can) which can be pushed out of the way without causing damage to gate motors.
- The operator should be switched off before repairing it or opening its cover.
- Our company reserves the right to change the design and specification without prior notification.

## 2. Main Technical Parameters

Model	ERMIS-8
Power supply	AC220(1±10%), 50Hz
Motor speed	1400 rpm
Gear teeth	19T
Gate moving speed	12m/min
Control unit	4033/3033
Max. gate weight	600 Kg
Output torque	14N·m
Limit switch	Spring limit switch
Noise	≤60 dB
Ambient temperature	-10°C~+50°C

### 3. Working Principle and Main Structure

ERMIS-8 all-in-one multifunctional sliding gate operator integrated the electric control board into the operator, it is composed of a single-phase motor, worm and worm gear, the main shaft of the motor rotates the worm with the clutch engaged, the worm rotates the worm gear and output gear, which pushes the rack attached to the sliding gate, thus moving the gate.

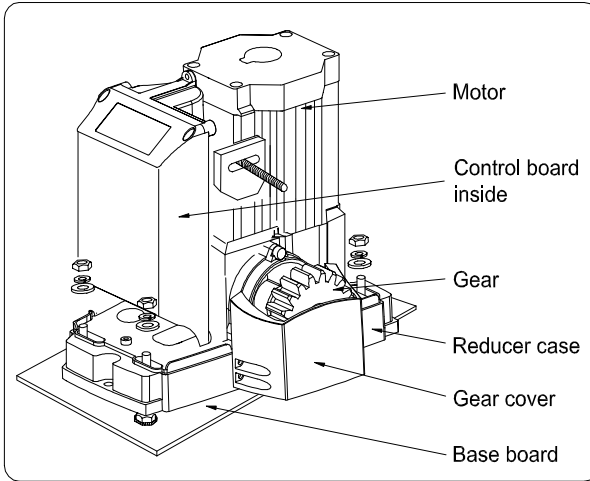

### 4. Installation and Adjustment

The ERMIS-8 rack-driven gate operator operates by forcing a drive rack past a drive gear. The entire configuration is shown in Fig.2 . The gate operator must be installed on the inside of the gate.

#### Gate preparation

Be sure the gate is properly installed and slides smoothly before installing the sliding gate operator. The gate must be plumb, level, and move freely.

## ERMIS-8 SLIDING GATE MOTOR UP TO 800KG

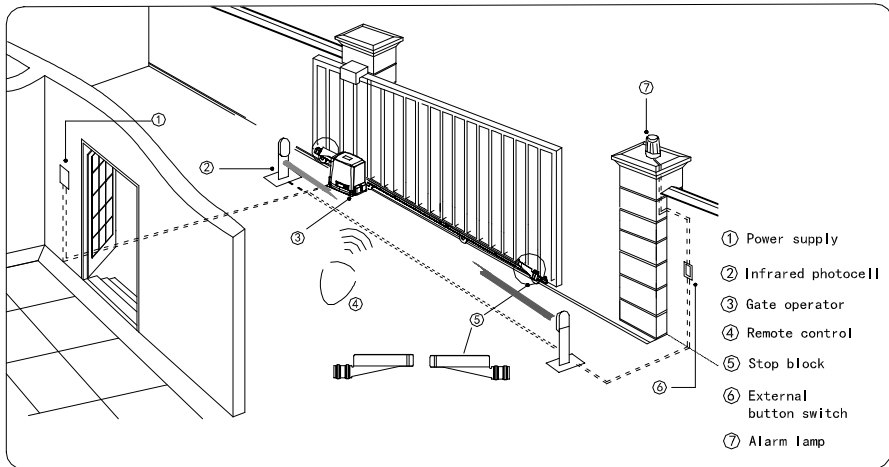

### Conduit

In order to protect the wires, use PVC conduit for wires, conduit must be set into the concrete when it is poured. Wires within the conduit shall be located or protected so that no damage can result from contact with any rough or sharp part.

### Concrete pad

The base unit of the gate operator requires a concrete pad in order to maintain proper stability. The concrete pad should be approximately 300mm x 200mm x 200mm deep in order to provide for adequate operation. The pad should be 70mm above finish grade. Be sure to locate the pad so that it will not interfere with the gate.

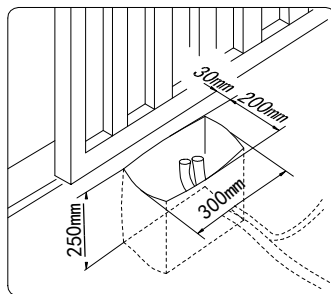

## ERMIS-8 SLIDING GATE MOTOR UP TO 800KG

### Anchors

You can use the anchors, bolts, washers and nuts that are provided with the operator see Fig.4. These anchors must be set into the concrete when it is poured, or you can use wedge expansion bolts.

### Operator base board

Mount the gate operator base board to the concrete pad see Fig.4. Verify that the operator is leveled properly.

### Operator

Mount the gate operator to the base board using nuts and washers.

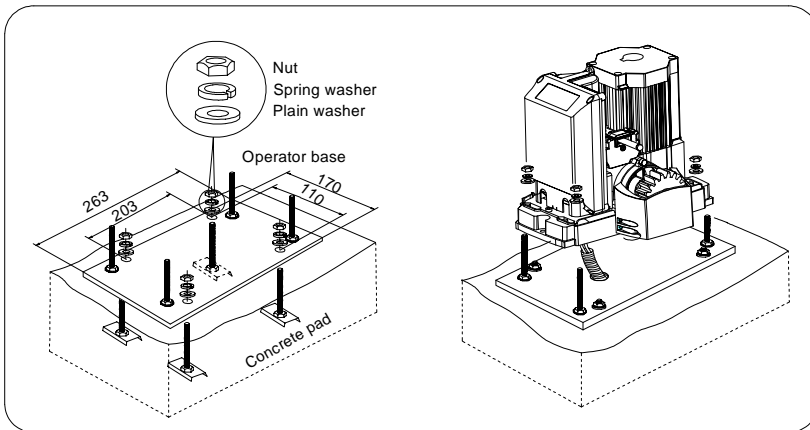

### Installing the rack

Weld the steel rack

- Manually move the gate to its closing position.
- Place the three threaded pawls (in the same package with rack) on the rack element.
- Lay the first piece of rack on the gear and weld the first threaded pawl on the gate.
- Move the gate manually, checking if the rack is resting on the gear, and weld the second and third pawls.
- The space between rack and gear is about 1mm.
- Bring another rack element near to the previous one. Move the gate manually and weld the three pawls as the first rack, thus proceeding until the gate is fully covered.
- When the rack has been installed, to ensure it meshes correctly with the gear.
- If necessary, assemble the spacer between the rack and pawl to synchronise the teeth of the two rack elements and keep racks in a straight line.

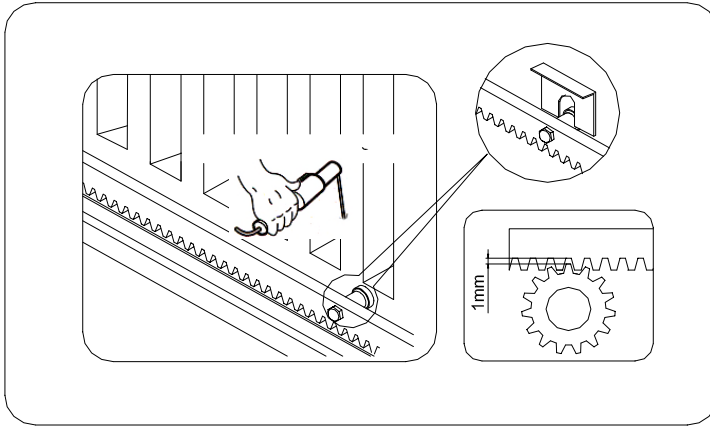

## Spring limit switch

Install the block as shown below. Release the gear clutch with the key and push the sliding gate manually to pre-determine the position, screw the block to the rack and then tighten the gear clutch with the key. Moving the gate electrically, adjust the block to the proper position until the position of the opening and closing meet the requirement.

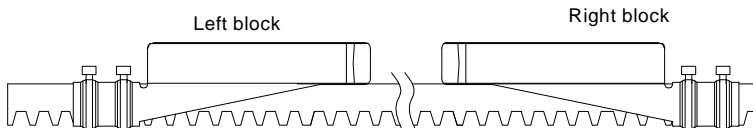
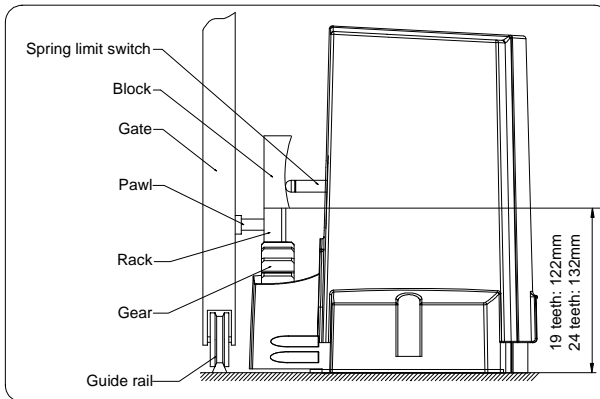

Screw the block on steel rack.

## ERMIS-8 SLIDING GATE MOTOR UP TO 800KG

### Manual operation

In case of power failure use manual release key to open or close gate manually, use the release key as follow:

- Remove the cover.
- Fit the supplied key in the hole.
- Turn the key counterclockwise to release the clutch.
- Pull the release lever.
- Open and close the gate manually.
- After power-restored close the release lever, then use the manual release key to engage the clutch by turning the key clockwise and resume normal operation.

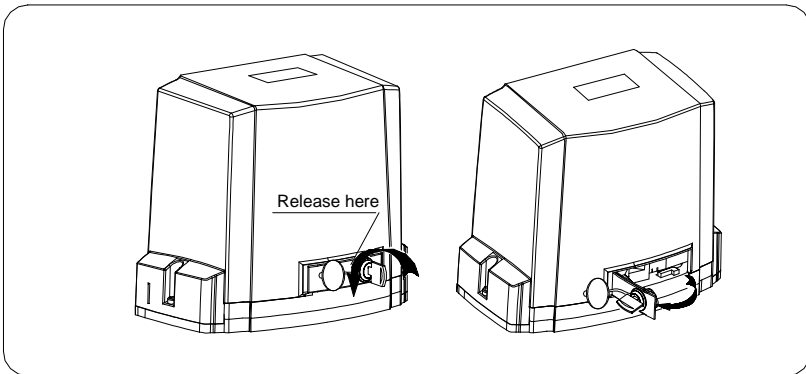

### 5. Final Check

- Check the power supply, grounding and wiring before running the device.
- Release the gear clutch with the release key to determine whether or not the gate can be moved manually. If everything is in good working order, tighten the clutch with the key.
- Switch on the power and run the device to ensure that the gate is sliding smoothly.
- Adjust the block position until the gate opened and closed properly at the limited positions.
- The gate operator is installed with a thermal protector, the motor is only designed to work for less than 15 minutes. If it runs continually for an extended period of time, the thermal protector will switch off the motor automatically in case of the temperature is higher than 120°C and switch on the motor when the temperature is lower than 85°C ± 5°C.

### 6. Maintenance

- Keep operator clean at all times.
- Ensure the operator is well earthed, and correctly terminated.
- Regularly grease the wheels and axles to ensure the gate moves smoothly.



## 7. DECLARATION OF CONFORMITY

In accordance with Annex II B of Machinery Directive 2006/42/CE , the importer L.PSARROS AND SIA OE



With the present we declare that the following products:

ERMIS-8 / ERMIS-4

is according to European Directives requirements of EMC 2006/42/EC and LVD Directive 2014/35/EU, satisfies all the applicable standards to the product within these directives as follows:

Applicable standards: EN 60335-1:2012/A13:2017

EN 60335-2-103:2015

EN ISO 12100:2010

EMC Directive 2014/30/EU

Certificate No.: TMC170417101-E

Applicable Standards: EN 55014-1:2017

EN 55014-2:2015

EN 61000-3-2:2014

EN 61000-3-3:2013

Athens, 29.01.2018

**Profelmnet**  
**Λ. ΨΑΡΡΟΣ ΚΑΙ ΣΙΑ Ο.Ε.**  
ΕΙΣΑΓΩΓΕΣ – ΚΑΤΙΕΣ ΜΕΚΤ. ΥΛΙΚΟΥ  
ΑΓ. ΔΗΜΗΤΡΙΟΥ 286Α Τ.Κ. 14242 ΑΓ. ΔΗΜΗΤΡΙΟΥ  
ΑΦΜ. 800845044 ΔΟΥ ΑΓ. ΔΗΜΗΤΡΙΟΥ  
ΑΡ. ΓΕ.ΜΗ. 142799401000  
ΤΗΛ.: 210 9850244 / FAX: 210 9823264